

IP Data Sheet

Linear Temperature Sensor

The TS_SN_TEMP_X8 is a temperature sensor generating an output voltage on VOUT, linearly increasing with junction temperature and trimmable to 2V at 60°C. It operates with a single supply voltage, VDDA4 (4V typical from the additional IP TS_VR_4V00_X8) and is meant for on-chip internal operation. Its inputs or outputs that need access to bond pads will require the insertion of ESD-protected buffers.

The DC load current through VOUT must be kept at

0A. The possible load may be either capacitive or the input resistor of an inverting integrator.

The minimum continuous operation lifetime spans 100000 hours.

Technology: XFAB XT018 - 0.18µm HV SOI CMOS

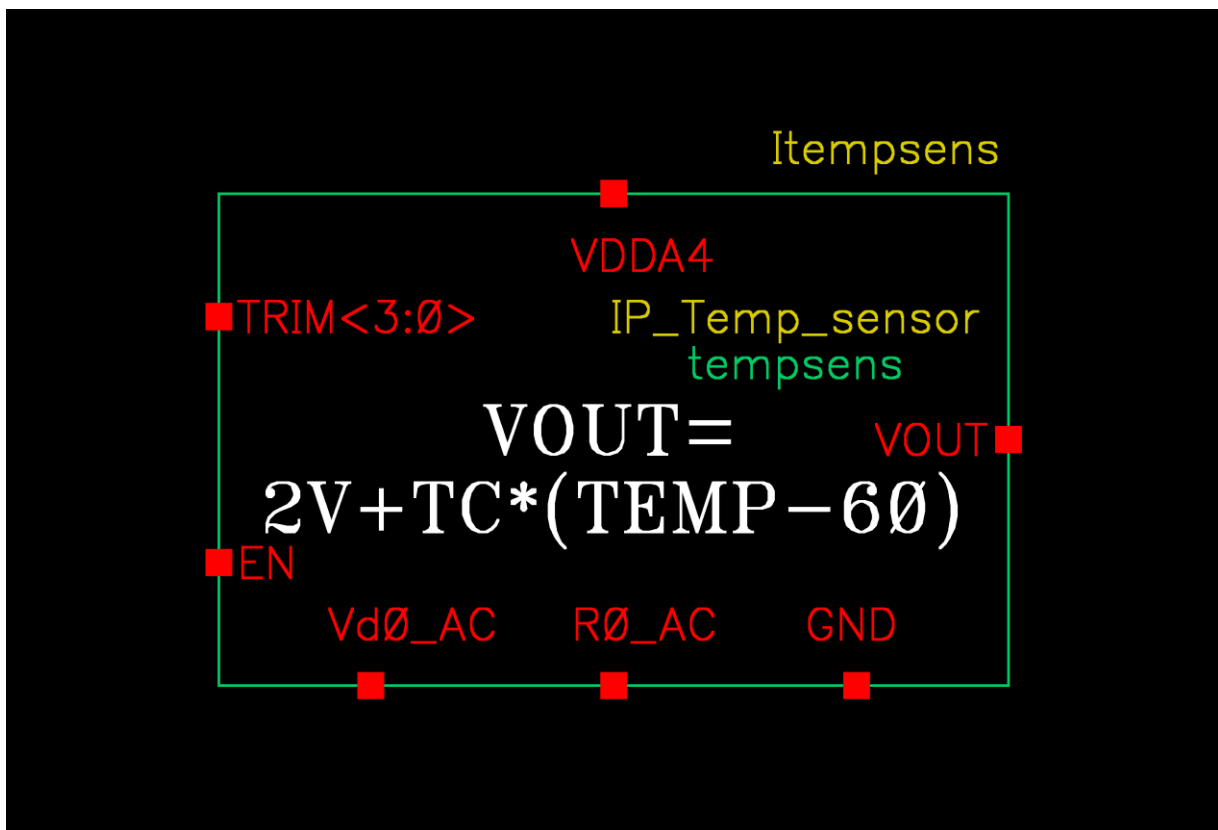

Operating conditions

Parameters	Values
Junction temperature range	20°C to +80°C
Supply voltages	VDDA4: 3.9V to 4.1V (supplied by the additional IP TS_VR_4V00_X8)
EN, TRIM<3:0> logic-high voltage level	VDDA4

Specification

Parameters	Values
Output voltage at T _J =60°C EN = H, TRIM<3:0> = LHHH, HLLL or HLLH	Minimum 1.995V, typical 2.000V, maximum 2.005V
V _{OUT} temperature coefficient EN = H, TRIM<3:0> = HLLL	Typical +6.2mV/°C
Total output noise level over 1Hz to 10MHz EN = H, TRIM<3:0> = HLLL	Maximum 0.3mV _{RMS}
Thermal response 3dB cut-off frequency EN = H, TRIM<3:0> = HLLL	Minimum 100Hz
Start-up time Unloaded V _{OUT} , EN toggling from L to H, TRIM<3:0> = HLLL	Maximum 10ms
Operating power consumption Enable EN high (H), TRIM<3:0> = HLLL	200μW max
Powerdown-mode current consumption Enable EN low (L)	100nA max
Area	0.117mm ²

V_{d0_AC} and R_{0_AC} must be interconnected. They are provided for temperature-response AC-analysis simulations only.

LAYOUT VIEW

